

Fresh water controller



Installation and operating instructions

Contents

	General safety instructions.....	3
	EC declaration of conformity.....	3
1	Proper usage	4
2	About this manual	4
2.1	Contents.....	4
2.2	Target audience	4
3	Installation	5
3.1	Opening / Closing the casing	5
3.2	Mounting the casing	6
3.3	Establishing the electrical connections.....	7
3.4	Terminal pin assignments.....	11
4	Structure	12
4.1	Casing.....	12
4.2	Display.....	12
5	Operation	14
5.1	Operating buttons	14
5.2	Display when operating.....	14
5.3	Setting the hot water temperature	14
6	Modes of operation	15
6.1	Changing the mode of operation	15
6.2	"Off" mode.....	15
6.3	"Manual" mode.....	15
6.4	"Automatic" mode.....	16
7	Deinstallation and disposal	18
8	Troubleshooting.....	18
8.1	General faults	19
8.2	Fault messages	20
9	Technical data	21
9.1	Controller	21
9.2	Cable specifications	21
	Exclusion of liability.....	22
	Legal guarantee	22
	Notes	23

General safety instructions

- This document is part of the product.
- Use the device only after reading and understanding this document.
- Keep this document in a safe place for the entire service life of the device. Pass this document on to subsequent owners and operators of the device.
- Adhere to all safety instructions. Consult (further) professional personnel in the event of any ambiguities.
- The measures described in this document may only be performed by qualified technical professionals. Exception: End-customers may operate the device when they have previously been trained by a technical professional.
- The system can be damaged by improper operation of the device.
- The device must not be connected to the power supply if it has an open or damaged casing.
- Factory labels and markings must never be altered, removed or rendered unreadable.
- Observe the prescribed conditions of use, see Section: *Technical data*.
- This device is not intended for:
 - Children
 - Persons with physical, sensory or mental impairment
 - Persons without sufficient experience or knowledge unless they are instructed in the use of the device, and initially supervised, by a person responsible for their safety.

EC declaration of conformity

This product conforms to the applicable European directives with regard to its design and its operating behaviour. This conformity has been verified. Further information in this regard can be obtained from your dealer.

1 Proper usage

The fresh water controller, subsequently referred to as the *controller*, is an independently installed electronic temperature controller for on-surface installation. Integration into a pump assembly is possible when the technical specifications of the controller are adhered to.

The maintenance-free controller is exclusively intended for controlling and monitoring fresh water stations.

2 About this manual

2.1 Contents

This manual contains all information required by a technical professional for setting up and operating the controller.

2.2 Target audience

The target audience of this manual are technical professionals who:

- have the knowledge of terminology and the skills necessary for setting up and operating fresh water stations.
- have the necessary training, knowledge and experience, and knowledge of the applicable regulations in order to evaluate and recognise the dangers inherent in the following work:
 - Installing electrical equipment
 - Cutting to size and connecting data communication cables
 - Cutting to size and connecting mains grid power supply cables

3 Installation

Note

The following section describes only the installation of the *controller*. Follow the instructions of each respective manufacturer when installing external components (pumps, storage tanks, valves etc.)

3.1 Opening / Closing the casing

3.1.1 Removing the front panel

- ▶ Grasp the front panel ① by the grooves at the sides ② and pull forwards ③ (Fig. 1).

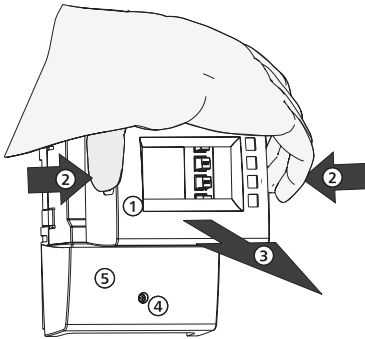

Fig. 1: Removing the front panel

3.1.2 Mounting the front panel

- ▶ Carefully position the front panel ① and then press it onto the casing until it latches into place.

3.1.3 Removing the terminal cover



Danger

Risk of death by electrocution!

- Disconnect the controller from the power supply before removing the terminal cover.
- Make sure that the power supply cannot be unintentionally switched on when the device is open.

1. Remove the screw (Fig. 1).
2. Remove the terminal cover ⑤.

3.1.4 Mounting the terminal cover

1. Position the cover ⑤.
2. Tighten the screw ④ to a torque of 0.5 Nm.

3.2 Mounting the casing

- ✓ The mounting location must satisfy the prescribed conditions of use; more information on this is provided in the *Technical data* section.
- ✓ The mounting surface is vertical and allows good access for installation.



Danger

Risk of death by electrocution!

- Disconnect the controller from the power supply before opening the casing.
- Make sure that the power supply cannot be unintentionally switched on when the casing is open.
- Do not use the casing as a drilling template.

1. If necessary, remove the terminal cover
2. Screw in the screw for the upper mounting hole ❶ (Fig. 2) until the screw head has a clearance of 5 ... 7 mm from the mounting surface.
3. Hang the controller on the screw by the upper mounting hole and align it vertically.
4. Mark the position of the lower mounting hole ❷ through the casing.
5. Remove the controller and prepare the mounting hole for the lower screw.
6. Hang the controller by the upper mounting hole ❶ and then fasten the screw in the lower mounting hole ❷.
7. Mount the terminal cover.

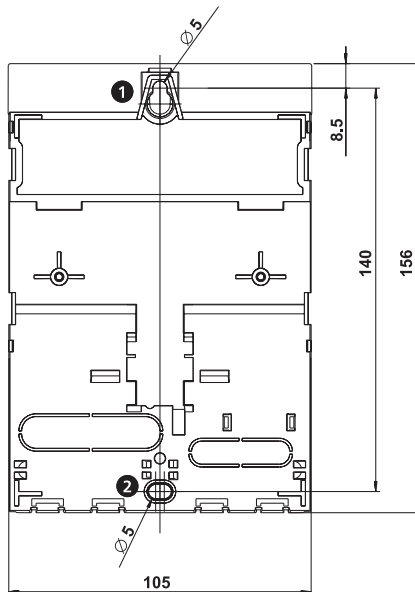

Fig. 2: Rear side of the controller with the upper ❶ and lower ❷ mounting holes

3.3 Establishing the electrical connections



Danger

Risk of death by electrocution! Make sure that the following conditions are satisfied when performing the work described in this section:

- All cables leading to the controller must be disconnected from the power supply and it must be ensured that they cannot be unintentionally reconnected during installation.
 - Each connection terminal must only be connected to a single conductor.
 - The protective earth conductors (PE) from the mains cable and pump and valve cables must be connected to the *protective earth conductor terminal block*.
 - All cables must be laid so that persons cannot stand on them or trip over them.
 - The cables must satisfy the requirements listed in the *Technical data* section.
 - The local power supply must match the specifications on the type plate of the controller.
 - The power supply cable is to be connected to the mains power as follows:
 - using a plug connected to a wall mains socket *or*
 - via an isolating mechanism allowing complete isolation in the case of permanent wiring.
 - The power supply cable must be laid in conformance to all applicable legal guidelines and regulations of the local electricity supplier.
-

Notice

Danger of damage and malfunction.

- Connect only components that do not overload the controller inputs and outputs; more information is provided on the type plate and in the *Technical data* section.
 - Speed control must be deactivated at output R1 when an external relay is connected.
-

Notes

- Lay the sensor cables at least 100 mm away from any power supply cables.
 - Use shielded sensor cables when inductive sources are present, e.g. high-voltage lines, radio transmitters, microwave devices.
-

3.3.1 Position of the connection terminals

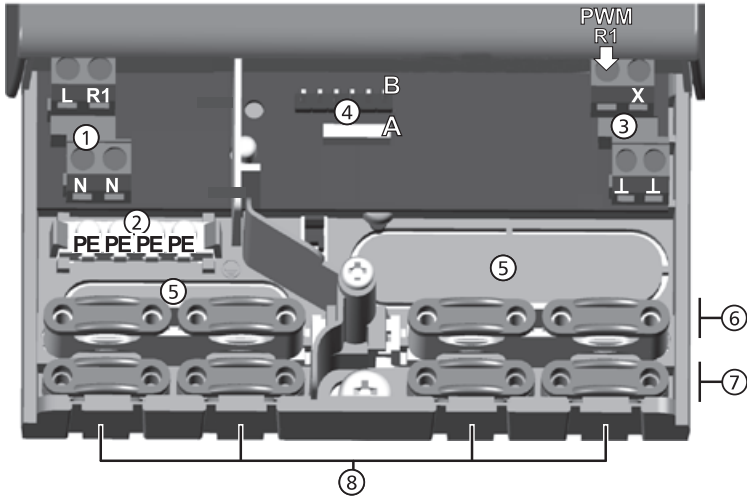

Fig. 3: Terminal clamps in the lower part of the controller (terminal cover removed)

①	<p>Power connection terminal block:</p> <p>L 1x phase conductor (mains input)</p> <p>R1 1x output (TRIAC, for pump)</p> <p>N 2x neutral conductor (common neutral conductors for mains power input and output)</p> <p>Note Output R1 is protected by an electronic fuse.</p>
②	<p>Protective conductor terminal block:</p> <p>PE 4x protective earth (common protective earth for <i>power connection</i> terminal block)</p>
③	<p>Signals terminal block:</p> <p>PWM R1 1x control output (for controlling a high-efficiency pump)</p> <p>⊥ 2x mass connection (common mass)</p> <p>X not used</p>
④	<p>A 1x 4-pin straight connector socket (for polarity-safe Molex plug to Grundfos Direct Sensors™ VFS or RPS *)</p> <p>B 1x pin strip, for internal use only</p>
⑤	Cable openings on the rear side of the casing
⑥	Upper strain relief clamps (2 identical plastic links, each with 2 strain relief clamps, supplied in the scope of delivery)
⑦	Lower strain relief clamps
⑧	Cable openings at the bottom of the casing

*) Grundfos Direct Sensors™ is a registered trademark of the Grundfos group.

3.3.2 Preparing the cable openings

The cables can be fed through openings in the rear wall of the casing or at the bottom of the casing. The openings are pre-punched and must be prepared as required before installation.

Prepare the cable openings in the rear wall of the casing as follows:

1. Break out the cable openings ⑤ (Fig. 3) using a suitable tool.
2. Deburr the edges.

Prepare the cable openings at the bottom of the casing as follows:

1. *Cut the required* cable openings ⑧ (Fig. 3) at the left and right using a suitable knife and break them out.
2. Deburr the edges.

3.3.3 Connecting the cables

- ✓ All cables are voltage-free.
- ✓ The cable openings have been prepared.

- ▶ Observe the following points when connecting the cables:
 - Connect the cable conductors to the correct terminals as described in the following *Terminal pin assignments* section.
 - Mains input and output: First connect PE, then N and L.
 - Strain relief:
 - First clamp the *lower* strain relief clamps and then the *upper* strain relief clamps.
 - When using the upper strain relief clamps, use the plastic links as described below.
 - If the opening in the strain relief clamp is too large, e.g. in the case of thin cables, turn over the strain relief clamping bar (with the bend facing down).
 - Only use the strain relief clamps for cables entering the bottom of the casing. Use external strain relief clamps when feeding cables through the rear of the casing.

3.3.4 Inserting/Removing plastic links

Insert the plastic links as follows:

1. Insert the right plastic link with the latching protrusion first ① (Fig. 4).
2. Press the other side of the plastic strip down ②, until the spring clamp latches into place.
3. Insert the left plastic strip the other way around (latching protrusion to the left, spring clamp to the right).

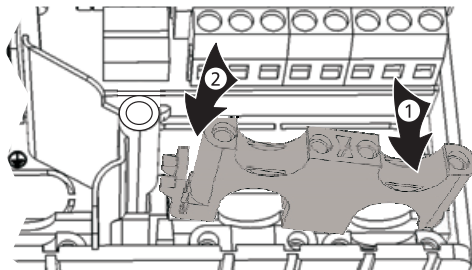

Fig. 4: Inserting the right plastic link

Remove the plastic links as follows:

1. Insert a flat-blade screwdriver under the right plastic link between the casing and the spring clamp ①, ② (Fig. 5).
2. Carefully push the screwdriver to the left ③. Lever the spring clamp ① to the right until the plastic link ④ is free.
3. Pull out the plastic link upwards by hand ⑤.
4. Remove the left plastic link accordingly.

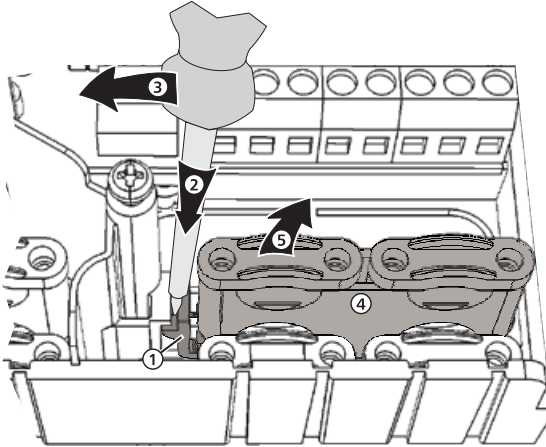

Fig. 5: Removing the right plastic link

3.4 Terminal pin assignments

The following diagram describes the controller terminals used for connecting external components.

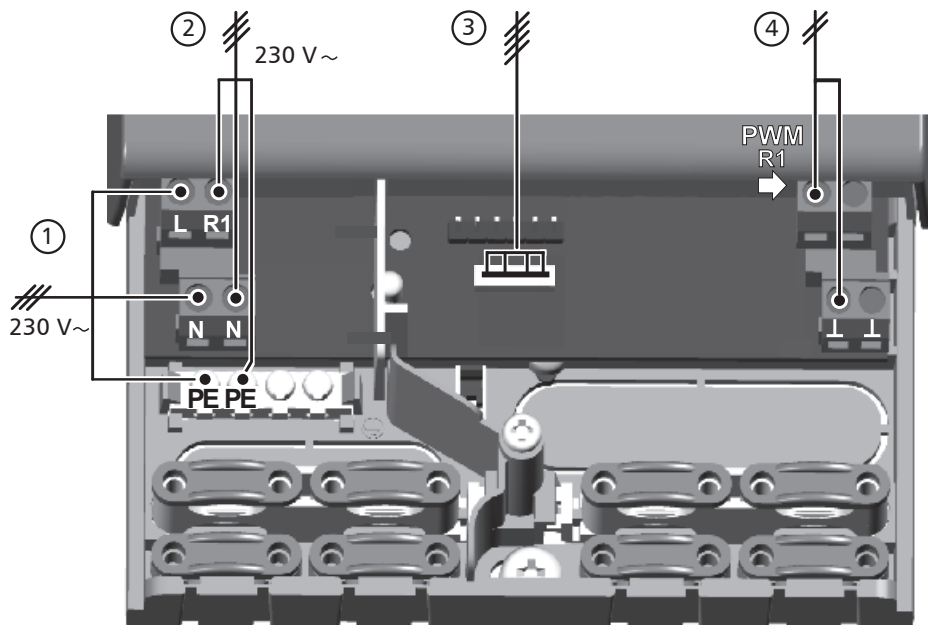
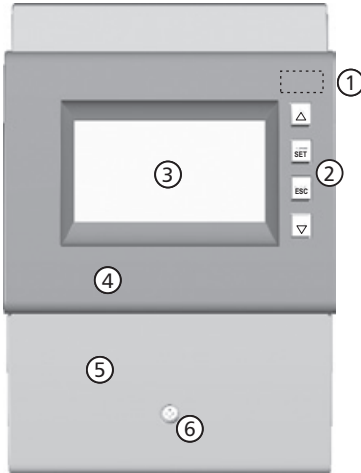



Fig. 6: Terminal pin assignments for the connected components

①	Mains input
②	Power supply of the pump/high-efficiency pump
③	Grundfos Direct Sensors™
④	Control cable for the high-efficiency pump

4 Structure

4.1 Casing



No.	Element	See Section
①	Mode  button (under front panel)	5.1 6
②	△, SET, ESC, ▽ operating buttons	5.1
③	Display	4.2
④	Front panel	3.1
⑤	Terminal cover	3.3.1 ¹⁾
⑥	Terminal cover fastening screw	–

¹⁾ Section 3.3.1 describes the terminals under the terminal cover.

Fig. 7: Front view of the controller

4.2 Display

4.2.1 Overview

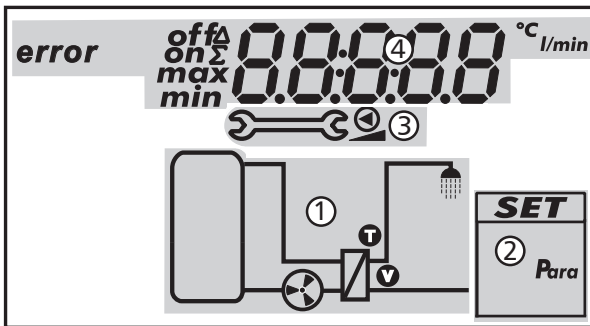











Fig. 8: Overview of the display areas (all elements visible)

①	System graphics
②	Settings menu
③	Pictograms for functions
④	Operational and setting values

The display areas are described below.

4.2.2 Symbols used

The following table describes the symbols used in Fig. 8.

Symbol	Description	Symbol	Description
—	Pipework		Pump, switched on
	External heat exchanger		Pump, switched off
	Domestic water outlet		Temperature sensor (Grundfos Direct Sensors™)
	Storage tank		Measuring device for the volume flow (Grundfos Direct Sensors™)
	Pump is speed controlled ¹⁾		Manual operation

¹⁾ Symbol is visible while the function/parameter is being edited in the settings menu.

4.2.3 Settings menu

The settings menu (② in Fig. 8) contains the entry *Para* (parameter).



4.2.4 Operational and setting values

The display of the operational and setting values (④ in Fig. 8) consists of the following elements:



①	Error display
②	Additional information: on, off: Switching state/condition <i>on</i> , <i>off</i> max, min: <i>Maximum</i> value, <i>minimum</i> value Σ: Summed operational value since first commissioning, cannot be reset Δ: Summed operational value since last reset to 0
③	Display of: <ul style="list-style-type: none"> • Measurements • Settings • Error codes • Additional information, e.g. software version
④	Physical unit of the value displayed in ③: °C, l/min

5 Operation

5.1 Operating buttons

The device is operated using the Δ , ∇ , SET, ESC and ⏏ buttons as follows:

Δ	<ul style="list-style-type: none"> Scrolling up through the menu Increases the setting value by 1 step
∇	<ul style="list-style-type: none"> Scrolling down through the menu Decreases the setting value by 1 step
SET	<ul style="list-style-type: none"> Selects a setting to be changed (setting value flashes) Confirms a setting value or jumps one level down in the menu structure Calls up the settings menu (not in <code>manual</code> mode)
ESC	<ul style="list-style-type: none"> Discards an entered setting Jumps up by one operating level
⏏	Sets the operating mode

Note

We recommend that you write down all settings that you have changed, e.g. in the Notes section.

5.2 Display when operating

- A flashing component in the system graphic means: The displayed operational or setting value applies to the flashing component.
Exception: ⏏ always flashes in `manual` mode.
- A flashing symbol is indicated in the figures by ⚡ .
- Displays that are automatically alternately displayed are shown overlapping in the figures. Example: Figure in Off mode section.

5.3 Setting the hot water temperature

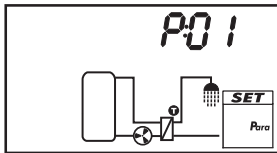

The controller attempts to adjust the hot water temperature to the set value. The hot water temperature can be changed in the settings menu via the parameter P:01 within the following limits.

Minimum:	20 °C
Maximum:	90 °C
Factory setting:	50 °C

Set the hot water temperature as follows:

- ✓ Automatic or Off mode is selected.
- Press and hold SET for two seconds. The settings menu is displayed, P:01 flashes.
 - Press SET. The set hot water temperature is displayed, the symbol ⚡ of the external heat exchanger flashes.
 - Press SET. The hot water temperature value flashes.
 - Press Δ/∇ to change the value.
 - Press SET to adopt the change.
 - Press ESC. P:01 flashes.
 - Press ESC. The status display appears.

6 Modes of operation

6.1 Changing the mode of operation

Notice

Danger of pump damage if run dry. Only switch the system to manual or automatic mode when the system is filled.

1. Remove the front panel.
2. Press the  button for 2 seconds to change the mode of operation.
3. Repeat step 2 if necessary.
4. Mount the front panel.

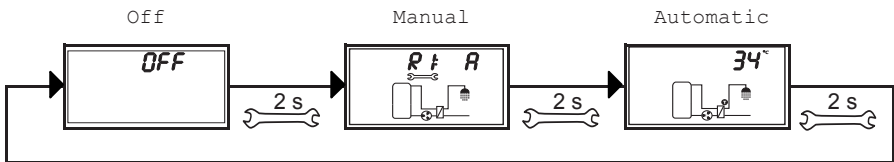

6.2 "Off" mode

Functionality

- The output is switched off (output/control output without power).
- OFF and the software version are displayed alternately. See example in Fig. below: Software version St 1.3
- Backlighting is red.
- Settings menu can be called up.
- The Off mode is preset when the device is delivered.

Operation

- ▶ Press and hold the SET button for 2 seconds to call up the settings menu (1).

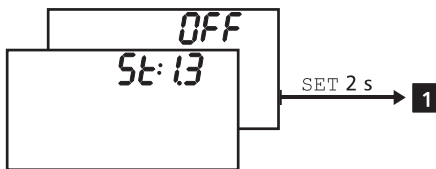

6.3 "Manual" mode

Functionality

- Backlighting is red, spanner symbol  flashes.
- The controller output (pump) can be manually switched. Possible switching states:
 - 0: off
 - 1: on
 - A: Automatic operation as per the settings in the settings menu
- Current temperatures and operating hours can be displayed (status display).
- When changing to manual mode the output is switched to A. R1 is displayed. Exception: Initial commissioning (output at 0).
- Typical application: Functional test (maintenance), fault-finding.

Operation

Switch the output on and off as follows **(2)**:

1. Press **SET**. The switching state flashes.
2. Press Δ/∇ to change the switching state.
3. Press **SET** to adopt the change.

Display the current temperatures, flow rate values and operating hours as follows:

1. Press **ESC**. The temperature/flow rate/operating hours are displayed and the associated component flashes **(3)**, display is not illustrated).
2. Press ∇/Δ to select a different component.
3. Press **SET** to leave the display.

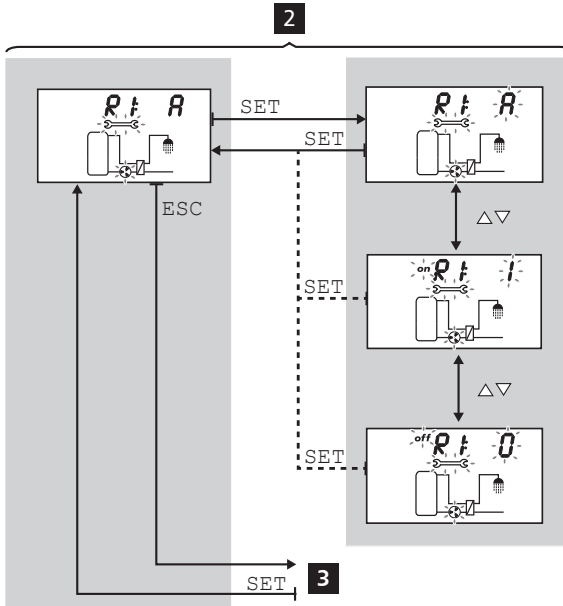

6.4 "Automatic" mode

Functionality

Automatic is the normal mode of operation and the system is automatically controlled. The following actions are possible:

- Display status (status display): Display the status of external components (temperatures, switching states, run times).
- Display stored min./max. values (temperature sensors) or sum/difference values (operating hours¹⁾ of the pumps and valves)
 - Summed values* (symbol Σ): Operating hours since first commissioning. Summed values cannot be reset.
 - Difference values* (symbol Δ): Operating hours since the last reset to 0.
- Reset the stored min./max./difference values.
- Call up the settings menu.

¹⁾ Summed switch-on times of the output

Operation

✓ The controller shows the status display.

You can display the status of external components as follows:

► Press $\Delta \nabla$ to display the status of other components (4, component flashes).

You can display and reset the stored min./max./difference values as follows:

1. Press $\Delta \nabla$ as required, in order to display other components (4, component flashes).
2. Press SET. The min./max./difference values are displayed alternately (5).
3. If desired, press and hold the SET button for 2 seconds to reset the currently (!) displayed value (6).
4. Press ESC. The status display is shown.
5. Repeat steps 1 to 4 if necessary.

Access the settings menu as follows:

► Press and hold SET for 2 seconds (7). The settings menu appears.

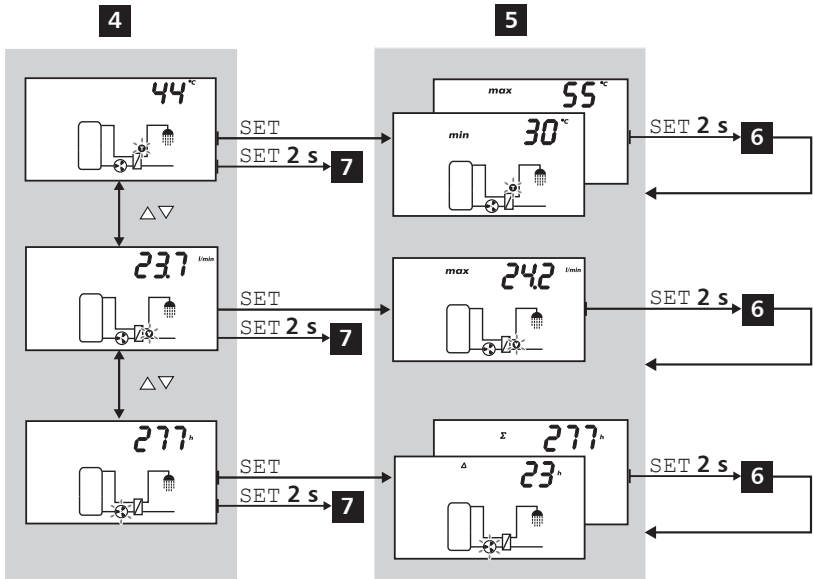

7 Deinstallation and disposal

**Danger**

Risk of death by electrocution!

- Disconnect the device from the power supply before opening the casing.
 - All work on an open device must be performed by professional personnel.
-

1. Deinstall the controller in the reverse sequence to installation; more information on this is provided in the *Installation* section.
2. Dispose of the device in accordance with the local regulations.

8 Troubleshooting

**Danger**

Risk of death by electrocution!



- Immediately disconnect the device from the mains supply when it can no longer be operated safely, e.g. in the case of visible damage.
 - Disconnect the device from the mains power before opening the case.
 - All work on an open device must be performed by professional personnel.
-

Notes

The controller is a quality product, conceived for years of continuous trouble-free operation. Observe the following points:

- Faults are often caused by connected components and not by the controller.
 - The following notes on fault identification indicate the most common causes of faults.
 - Only return the controller when you are absolutely sure that none of the problems listed below is responsible for the fault.
-

8.1 General faults

Display	Possible cause	Solution
Controller not functioning at all		
Display empty/dark	Controller power supply is interrupted.	<ul style="list-style-type: none"> Check the controller power cable. Check the fuse for the power supply.
Pump is not running but drinking water is being drawn off.		
The pump symbol rotates.	Pump power supply is interrupted.	Check the pump power cable.
	Pump has seized up.	Get the pump working again.
The pump symbol does not rotate.	Hot water temperature has been reached.	No fault.
<ul style="list-style-type: none"> The pump symbol does not rotate. Display is red.  flashes 	Manual mode is switched on, output R1 is set to 0 (off).	Switch to automatic mode.
<ul style="list-style-type: none"> The pump symbol does not rotate. The display flashes red. 	Short circuit or interruption of the temperature sensor.	<ul style="list-style-type: none"> On the controller, request the current values from the connected temperature sensors. Check the sensors and cables.
Pump is running but drinking water is not being drawn off.		
The pump symbol rotates.	Pump is running due to blockage protection.	No fault.
Grundfos Direct Sensors™ shows a flow but no drinking water is being drawn off.	Grundfos Direct Sensors™ is not grounded correctly.	Ground Grundfos Direct Sensors™: Connect a cable between the terminal \perp (see © on Page 8) and the metal pipe in the direct vicinity of Grundfos Direct Sensors™.
<ul style="list-style-type: none"> The pump symbol rotates. Display is red.  is displayed. 	Manual mode is switched on, output R1 is set to 1 (on).	Switch to automatic mode.
No heat transport in heat exchanger, pump is running, drinking water is being drawn off.		
The pump symbol rotates.	Air in system.	Check the primary circuit for air.
	The isolating valve is closed.	Check/open the isolating valve.
	Heat exchanger is dirty or calcified.	Flush/clean the heat exchanger in accordance with the manufacturer's instructions.
Pump shows cycle behaviour.		
–	Air in system.	Check the primary circuit for air.
	The isolating valve is closed.	Check/open the isolating valve.
	Heat exchanger is dirty or calcified.	Flush/clean the heat exchanger in accordance with the manufacturer's instructions.

8.2 Fault messages

Faults are displayed as shown below, the backlighting is red.

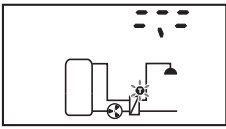
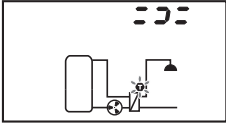
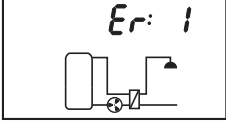
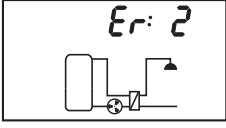
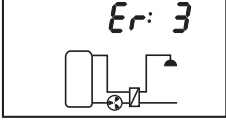
Display (example)	Description	Solution
	An interruption was detected at a sensor input of Grundfos Direct Sensors™ (temperature or volume flow).	Check the cable and Direct Sensors™ connected to the sensor input.
	A short-circuit was detected at a sensor input of Grundfos Direct Sensors™ (temperature or volume flow).	Check the cable and Direct Sensors™ connected to the sensor input.
	The <i>target hot water temperature</i> has not been reached. Possible causes: <ul style="list-style-type: none"> • The storage tank is not heated up. • The isolating valve in the primary circuit is closed. • Air is in the pipes. • The pump is faulty. • The heat exchanger is dirty or calcified. 	<ul style="list-style-type: none"> • Heat up the storage tank. • Check the isolating valve. • Bleed the pipes. • Check the pump. • Decalcify/clean the heat exchanger.
	A short-circuit exists at output R1, the pump flashes. Possible causes: <ul style="list-style-type: none"> • The pump is faulty. • Wiring fault 	<ul style="list-style-type: none"> • Check the pump. • Check the wiring to R1.
	Output R1 is overloaded, the pump connected to output R1 flashes. Cause: The permissible values for R1 specified on the type plate have been permanently exceeded, the output has been switched off.	Check the electrical data of the pump, replace pump if necessary. R1 is automatically switched on again.

9 Technical data

9.1 Controller

Inputs/outputs							
Rated voltage (system voltage)	115 ... 230 V~, 50/60 Hz						
Own consumption	< 1 W (Standby)						
Output R1	<table border="0"> <tr> <td style="text-align: right;">Quantity</td> <td>1</td> </tr> <tr> <td style="text-align: right;">Type</td> <td>TRIAC</td> </tr> <tr> <td style="text-align: right;">Switching current</td> <td>1.1 (1.1) A each</td> </tr> </table>	Quantity	1	Type	TRIAC	Switching current	1.1 (1.1) A each
Quantity	1						
Type	TRIAC						
Switching current	1.1 (1.1) A each						
Signal inputs/outputs							
Signal input Direct Sensors™	<table border="0"> <tr> <td style="text-align: right;">Quantity</td> <td>1</td> </tr> <tr> <td style="text-align: right;">Supply voltage</td> <td>5 V= +5 %</td> </tr> <tr> <td style="text-align: right;">Output current</td> <td>≤ 10 mA</td> </tr> </table>	Quantity	1	Supply voltage	5 V= +5 %	Output current	≤ 10 mA
Quantity	1						
Supply voltage	5 V= +5 %						
Output current	≤ 10 mA						
Signal output PWM R1	<table border="0"> <tr> <td style="text-align: right;">Type</td> <td>PWM, 250 Hz, 11 ... 12 V; characteristics: 0% PWM = pump off, 100% PWM = maximum speed</td> </tr> <tr> <td style="text-align: right;">Max. load</td> <td>10 mA</td> </tr> </table>	Type	PWM, 250 Hz, 11 ... 12 V; characteristics: 0% PWM = pump off, 100% PWM = maximum speed	Max. load	10 mA		
Type	PWM, 250 Hz, 11 ... 12 V; characteristics: 0% PWM = pump off, 100% PWM = maximum speed						
Max. load	10 mA						
Hydraulic schemes (systems)							
Quantity	1						
Display							
Type	LCD display with backlighting						
Application conditions							
Degree of protection	IP22, DIN 40050 [without front panel: IP20]						
Protection class	I						
Ambient temperature	0 ... +50 °C, when wall-mounted						
Physical specifications							
Dimensions L x W x H	110 x 160 x 51 mm						
Weight	350 g						
Software class	A						
Type of action	type 1.Y						
Type of fastening for permanently connected cables	type X						
Degree of pollution	2						
Ball pressure test temperature	casing pan: 125 °C; other casing parts: 75 °C						
Overvoltage category	class II (2500 V)						

9.2 Cable specifications

Mains cable	
Mains cable type	H05 VV-... (NYM...)
External diameter of mantle	6.5 mm to 10 mm
Conductor cross-section	
single strand (solid)	≤ 2.5 mm ²
fine strand (with core end sleeves)	≤ 1.5 mm ²
Diameter of the internal strain relief	6.5 mm to 10 mm

Exclusion of liability

The manufacturer can neither monitor the compliance with this manual nor the conditions and methods during the installation, operation, usage and maintenance of the controller. Improper installation of the system may result in damage to property and, as a result, to bodily injury.

Therefore, the manufacturer assumes no responsibility and liability for loss, damage or costs which result from or are in any way related to incorrect installation, improper operation, incorrect execution of installation work and incorrect usage and maintenance. Similarly, we assume no responsibility for patent right or other right infringements of third parties caused by usage of this controller.

The manufacturer reserves the right to make changes to the product, technical data or installation and operating instructions without prior notice.

Legal guarantee

In accordance with German statutory regulations, there is a 2-year legal guarantee on this product for the customer.

The seller will remove all manufacturing and material faults that occur in the product during the guarantee period and affect the correct functioning of the product. Natural wear and tear does not constitute a malfunction. No legal guarantee can be offered if the fault can be attributed to third parties, unprofessional installation or commissioning, incorrect or negligent handling, improper transport, excessive loading, use of improper equipment, faulty construction work, unsuitable construction location or improper operation or use. Legal guarantee claims shall only be accepted if notification of the fault is provided immediately after it is discovered. Guarantee claims are to be directed to the seller.

The seller must be informed before guarantee claims are processed. For processing a guarantee claim an exact fault description and the invoice / delivery note must be provided.

The seller can choose to fulfil the legal guarantee either by repair or replacement. If the product can neither be repaired nor replaced, or if this does not occur within a suitable period in spite of the specification of an extension period in writing by the customer, the reduction in value caused by the fault shall be replaced, or, if this is not sufficient taking the interests of the end customer into consideration, the contract is cancelled.

Any further claims against the seller based on this legal guarantee obligation, in particular claims for damages due to lost profit, loss-of-use or indirect damages are excluded, unless liability is obligatory by law.

Notes



745089