

Datasheet and Operating Instructions

HS200 current sensor for Tarom and PowerTarom

General information :

Solarsystems with a Tarom systemmanager can be quite complex. Due to the high power going in and out the battery it is commonly necessary to connect the load or external chargers directly to the battery. The high sophisticated state of charge (SOC) algorithm of the Tarom needs to know about this external currents which are not going through the Tarom regulator. The current sensor HS200 registrates and transmits these information to the Tarom controller. The HS200 can be mounted next to the battery. The main wire coming from the battery runs through the HS200 case (see picture) and all incoming and outgoing currents are recorded and digitally transmitted to the Tarom. Since the current measurement is potential free using a magnetic hall sensor it is not necessary to cut off the wire and insert a shunt resistor. There is no loss of energy or any voltage drop during measurement.

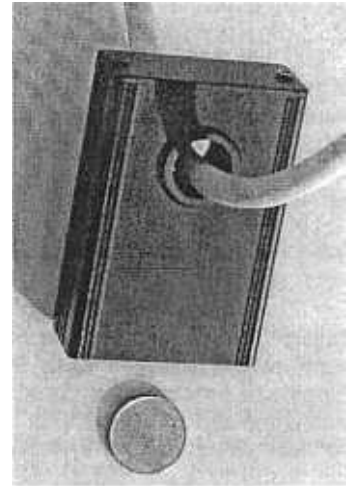

current sensor HS200

technical overview :

The HS200 enhances your Tarom System Manager to work together even with huge external chargers or loads. The state of charge calculation will be improved and enables the external load switch PA15 to work optimal in your system.

All data coming from the HS200 will be stored in the datalogger TarCom, too.

The HS200 is connected to the Tarom regulator via a regular RJ45 cable. The power supply and data transfer runs through this cable. There are three different sensor modes: battery, load, charge. In "battery mode" the HS200 detects all currents through the main battery cable, in "load mode" the sensor is used to detect only the external loads not connected to the load output of the Tarom/PowerTarom. In "charge mode" all external charging devices (diesel generators, wind generators or else) which are not controlled by the Tarom module input run through the HS200.

Alle current values are transmitted to the Tarom/PowerTarom every 20 seconds. These values will be combined with the currents through the Tarom regulator and displayed on the LC-display and stored in an eventually attached data logger TarCom. Each data transmission is visualized by the info LED on the side of the HS200.

Input: two RJ45 sockets for Tarom/PowerTarom, data logger TarCom or temperature sensor.

output: LED for function control, digital output to the Tarom.

Technical Data		HS200
Nominal system voltage (via Tarom)	U_{sys}	12-48V
quiescent current	I_q	$\leq 9mA$
current range "battery mode"	I	+/- 200A
current range "charge mode"	I	0 .. +200A
current range "load mode"	I	-200 .. 0A
precision -20 .. +20A	I_{res}	+/- 1%
precision -200 .. +200A	I_{res}	+/- 3%
sample/transfer interval	t	2/20 s
operating temperature range	TA	-15...50°C
max. admissible humidity		75 %
ingress protection of enclosure		IP 22
case		aluminium
max. cable diameter for current sensor		16 mm \varnothing
overall dimensions		100 x 60 x 25mm
weight incl. accessories		120g

installation:

Before installation you have to decide which part of the system currents the HS200 should monitor. There are three different configurations for the HS200: a battery sensor, load current sensor or charge current sensor. By using only one sensor and to obtain an optimal SOC calculation you should use it as a battery sensor. If you only want to see the in or out going currents outside the Tarom-regulator you can install it as a charge/load sensor.

Set the configuration switch (next to the LED) the desired position: 1. load sensor, 2. battery sensor, 3. charge sensor. Note: The sensor type can only be changed before starting operation. All switching during operation will be ignored!

Lead the choose DC main cable through the hole in the HS200 case. Check the right direction (+ / -) on the HS200 case !

Then attach the included RJ45 patch cable to the Tarom regulator. In systems with a datalogger you can use the second plug in the logger case. If an optional temperature sensor is used you can plug it into the remaining plug on the HS200.

See illustration for proper installation.

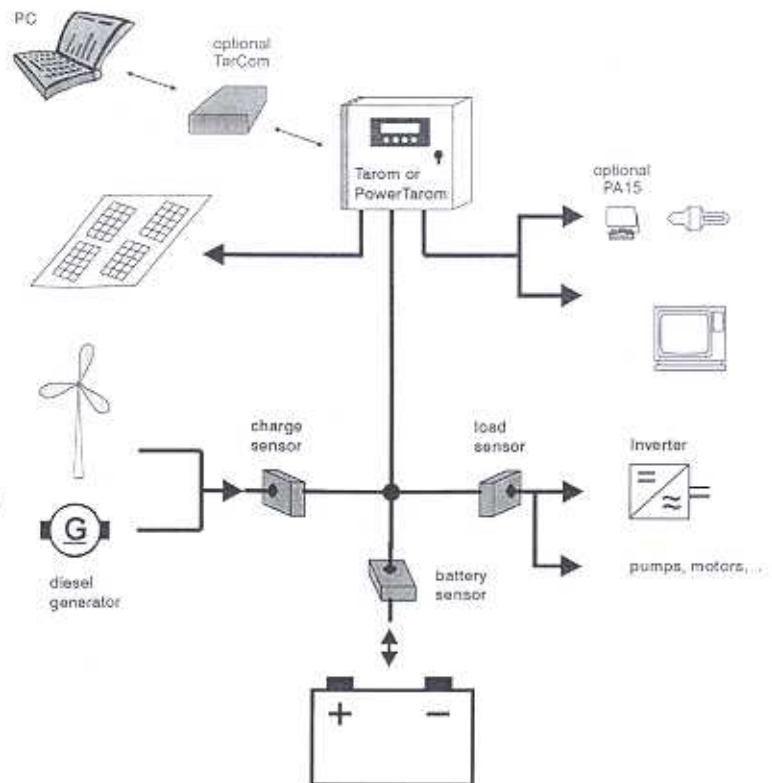

HS200 together with Tarom System Manager

operation:

After installation the Tarom regulator gets each 20 s the actual current values from the HS200. Each data transmission is visualized by the blinking green info LED. The data on the LC-display of the Tarom is actualized every 20 s. The current value is the averaged data during this 20 s period.

Currents over 200A will be recorded as 200A, the sensor will not be harmed in any way by the over currents. Since the data sampling interval is 2 seconds, short peak currents are not sure to be recorded.

hints:

Make sure to install the current sensor cable in the right direction. With the wrong orientation you will get senseless current indications in the LC-display of the Tarom and the SOC calculation will fail. This can lead to an improper deep discharge protection of the system but the battery charging will not be influenced.

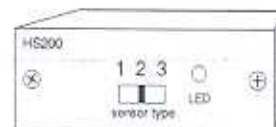
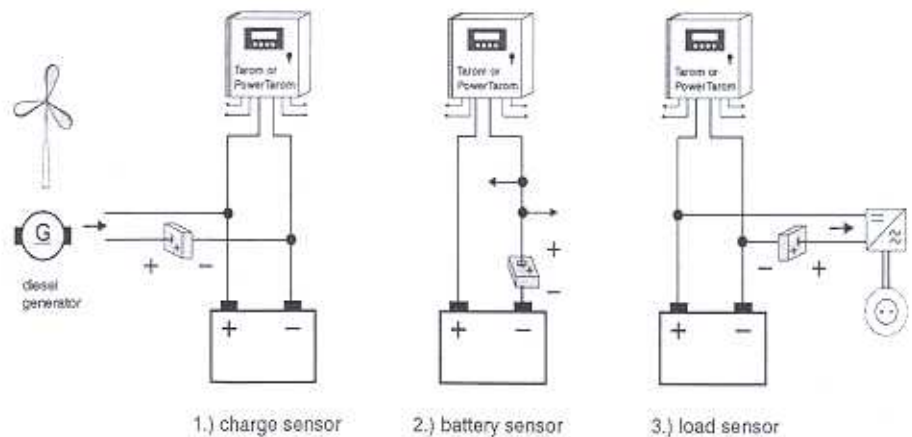

Three HS200 configurations